



## CUSTOM INSTALLATION GUIDANCE FOR MOLOKAI SOLAR OBSTRUCTION LIGHTING

September 20<sup>th</sup>, 2108

Paul Longley, Sales Engineering  
plongley@carmanah.com 250-412-8367



The following document provides an overview on how to connect together the complete Flash red medium obstruction lighting and Ameresco solar power system that was shipped to Molokai. Three systems in total shipped. This document is arranged in four (4) parts:

- A. General information about the individual components
- B. Mounting the components
- C. Connecting the components together
- D. Wiring schematic

Within this document, the terms “array” and “PV” refer to the solar panel.

**NOTE**

Among the various attached files, the user manual “7913801-FTS-371-Product-Manual-Rev3.pdf” and the quick start guide “F7904219-FTS-371-Vanguard-QSG-DC-Basic-REV2.pdf” are particularly useful and should be reviewed. A wiring schematic providing a complete overview of the system is provided in section D.

**ADDITIONAL PARTS REQUIRED**

For a complete installation, there are additional parts that must be provided by the end user:

- Mounting fasteners for the FTS 371 Controller
- 4 cable glands – 3 for FTS 371 Controller and 1 for the third hole in solar system enclosure
- Jacketed #12AWG 2-conductor with ground power cable between solar system and FTS 371 Controller
- Solar panel mounting hardware if not mounting to 2” SCH pole
- Solar system enclosure mounting hardware if not mounting to 2” SCH pole
- Grounding

**SYSTEM GROUNDING** 

The entire system, including solar system enclosure, solar panel and mount, FTS 371 Controller and Flash Head should be well-grounded according to local electrical code and directions provided in the Flash FTS 371 User Manual.

## A. GENERAL INFORMATION

---

### ABOUT THE SOLAR PANEL

Each system uses one (1) 85-watt 24-volt Solartech SPM085P-WP-F solar panel. Electrical connections are made at the solar panel by flipping open the back of the junction box, removing the knockouts to create holes for the wiring, connecting the solar cables to the junction box, attaching the wires to the positive and negative terminals, and closing the junction box.

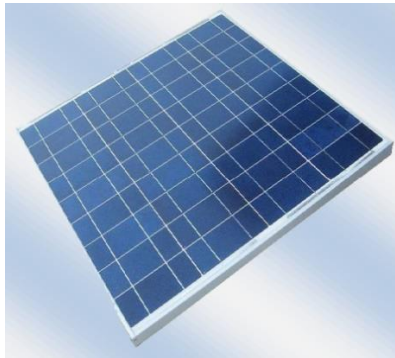

See attached spec sheet “SPM085P-WP-F.pdf”.

For each panel, two (2) 15-foot lengths of 10-gauge solar panel wiring are provided including gland connectors at each end. Together, the pair of wires form the positive and negative connections for the solar panel.



Single-Conductor PV Cable (2 provided per system – 1 for positive, 1 for negative)



Close-up of PV Cable Ends Showing Cut Wire Ends and Gland Connectors

#### **ABOUT THE SOLAR PANEL SIDE-OF-POLE MOUNT**

Each system has been provided with a side-of-pole mount for the solar panel. The mount attaches to a 2" SCH pole. If the intended mounting structure is not a 2" SCH pole, lag bolts maybe used to secure the brackets to a structure.

See attached spec sheet "1X-SPM.pdf"



#### **ABOUT THE ENCLOSURE**

The enclosure is a model BBA-2. It supports two (2) Group 31 batteries and is equipped with:

- Electrical backplate (details below)
- Two mounting tabs
- Rain drip lip
- Double-flanged door opening
- Stainless steel hinge
- NEMA 3R water-resistance
- Louvered vents with screens
- Closed cell neoprene gasket
- Stainless lockable draw latch

- Two (2) ½" NPT Knock-outs

See spec sheet "BBA-2-Enclosure.pdf"

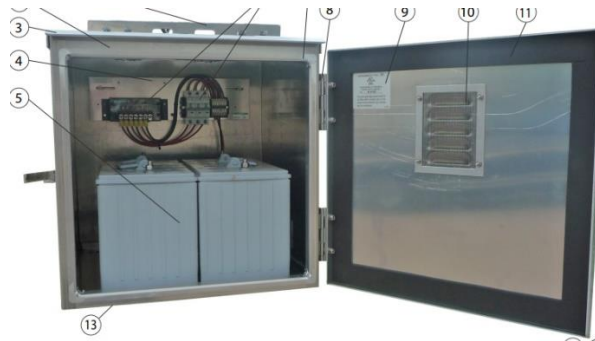

A Similar 2-Battery System

Inside the enclosure is a pre-wired backplate assembly equipped with:

- ASC 24-volt 8-Amp charge controller
- DIN rail with three 10-amp breakers and six terminals blocks
- Battery cables #10AWG red and black with ring terminals

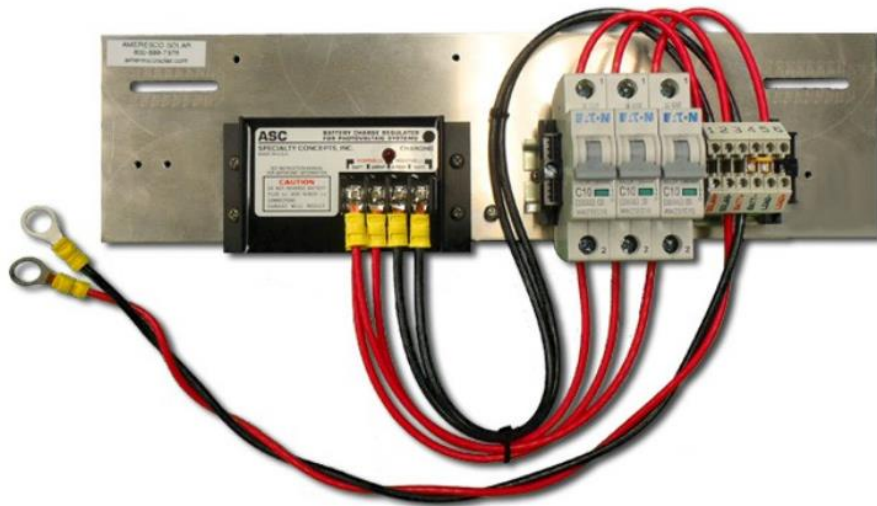

The enclosure is equipped with two (2) 108 amp-hour Group 31 12-volt Deka 8G31 solar batteries connected in series to produce nominal 24 volts.

See attached battery spec sheet "8G31\_DEKA.pdf"

#### ABOUT THE FLASH 371 FTC CONTROLLER

**NOTE**

Refer to FTS User Manual "7913801-FTS-371-Product-Manual-Rev3.pdf" and spec sheet "FTS 371 Data Sheet.pdf"

Your Flash controllers will look similar to the following images. These images show an AC-powered version of the controller. The DC-powered versions at Molokai will have very similar terminal blocks.

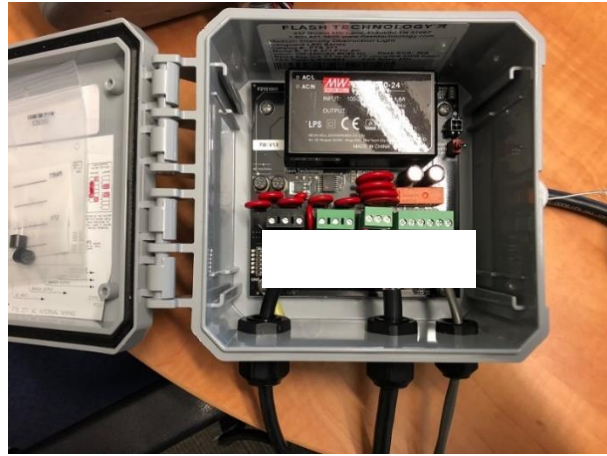

AC-Version of FTS 371 FTC Controller – DC Version has same layout of terminal blocks

Three cables will enter the controller through cable glands in the bottom of the controller. From left to right, these cables are:

1. 24-volt DC power from the solar system
2. Flash Head power
3. Photodiode

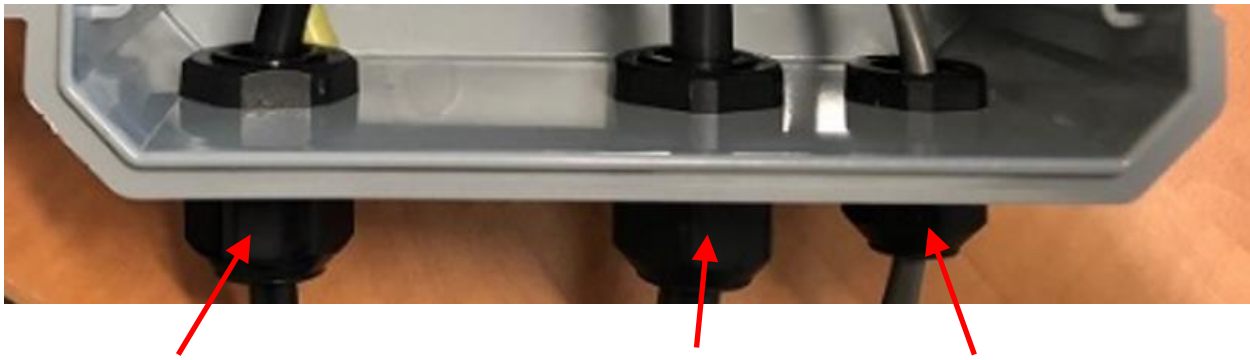

**24-volts DC Power from solar system**

**Flash Head Power**

**Photodiode**

**NOTE**

The FTS 371 FTC Controller does *not* ship with predrilled holes or cable glands for cable ingress. Users are responsible for obtaining the 3 cable glands, drilling the correctly-sized holes, and installing the cable glands when the cables are being attached. These holes should be drilled before mounting the controller. A step drill is recommended for this step. To minimize the risk of damage to the controller circuit board, Carmanah strongly recommends the circuit board be removed prior to drilling. Removal is easy and requires removing only 4 easily-accessed screws. Take the necessary precautions against ESD (Electrostatic Discharge) that could damage the electronics during handling.

### ABOUT THE FLASH 371 FH RED MEDIUM INTENSITY FLASH HEAD

The Flash 371 flash head is a 24-volt, medium-intensity obstruction light. It is basically a “dumb” fixture that turns on and off when the controller tells it to.

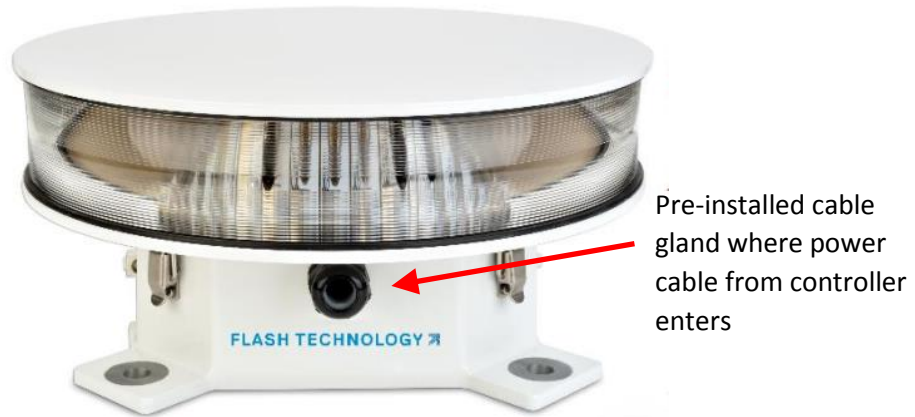

### ABOUT THE PHOTODIODE

Each system is provided with a photodiode Part # F1855516 that is used to determine whether it is day or night and therefore whether the flash head needs to be dark or flashing. The photodiode is provided with 20 feet of pigtail wiring with white, black, and braided metal conductors. The photodiode connects to the FTS 371 controller, not the flash head.



## B. MOUNTING THE COMPONENTS

---

### NOTE

Before you begin mounting equipment, take into consideration the cable lengths when spacing out equipment. For example, the solar-panel-to-enclosure cables are 15 feet in length. Ensure that the solar panel and the enclosure are close enough that the cables can be terminated on each end and leave a comfortable amount of slack in the cable.

### MOUNTING THE SOLAR PANEL

Instructions for attaching the solar panel to the side-of-pole mount and attaching the mount to a pole will have been included with the mounting hardware package. The hardware provided with each system is sized for mounting to a 2" SCH pole. Each system is provided with six (6) U-Bolts. If the provisioned u-bolts do not match the diameter of the pole, or if another structure altogether is being used, different u-bolts, lag screws or other hardware will be needed to mount the solar panel. For side-of-pole mounting, 4 u-bolts are used – two on the top bracket and two on the bottom bracket. Ensure the solar panel is mounted in a position that is clear of shading from trees or other obstructions. Point the solar panel true south (not magnetic south) and adjust the distance between the two support rails to **set the solar panel inclination angle to 35 degrees**.

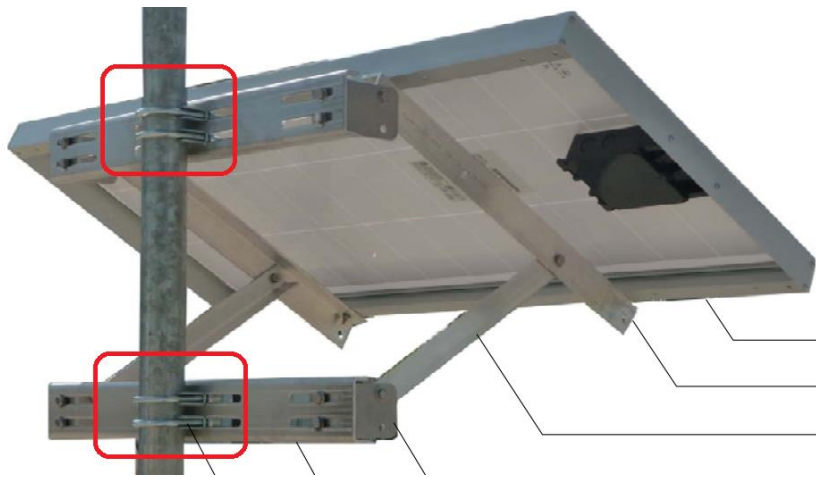

Four U-Bolts for Mounting Side-of-Pole Mount



Close-up of U-Bolts

## MOUNTING THE ENCLOSURE

After the solar panel is mounted by using four of the six u-bolts, the remaining two u-bolts are used to mount the enclosure to the side of a pole. The enclosure mounts on a 2" SCH 40 pole. If the enclosure needs to be mounted to a different surface or structure, a different u-bolt arrangement can be used, or lag bolts can be used with the top and bottom mounting tabs.

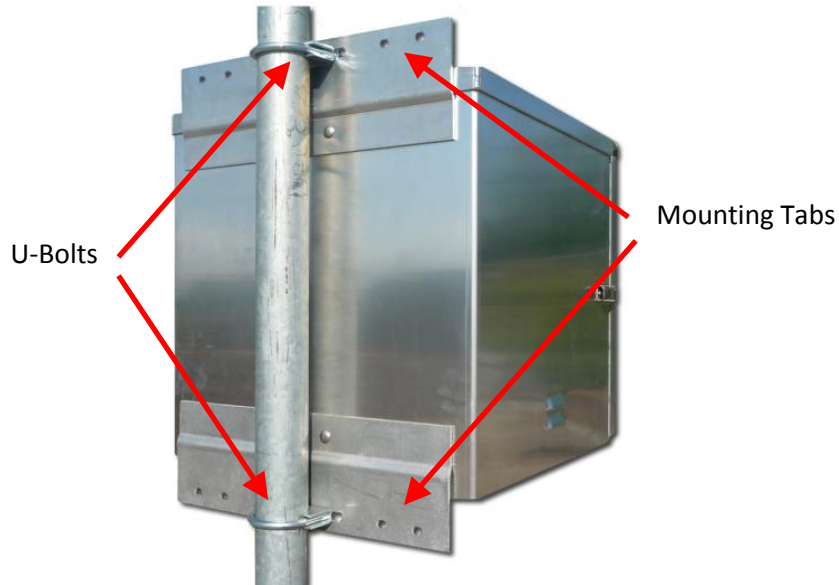

## MOUNTING THE CONTROLLER

The FTS 371 controller has six mounting holes as shown in the following diagram.

**NOTE** Given the variety of installation options for the controller, users are responsible for determining and providing the correct fasteners for mounting the controller.

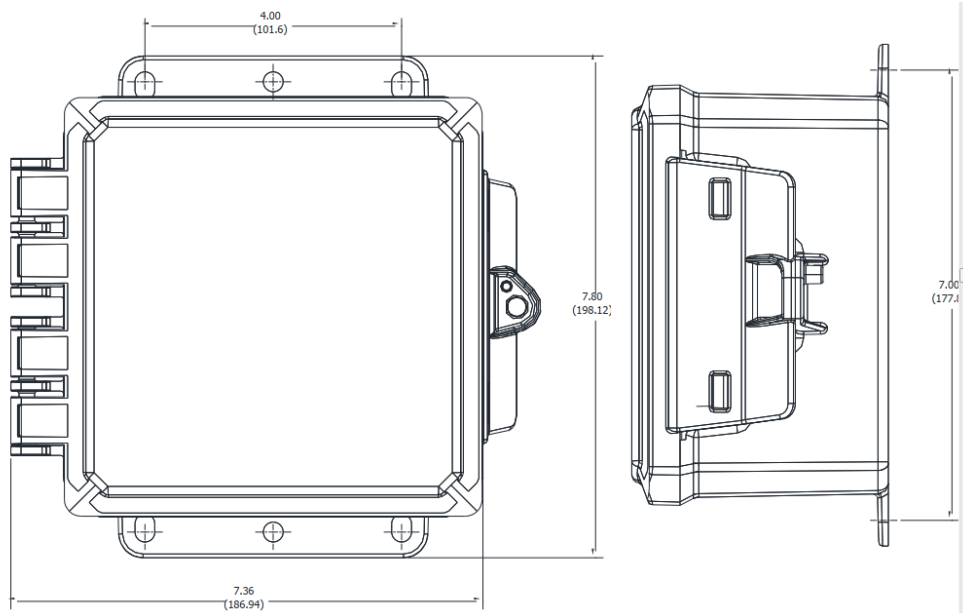

## MOUNTING THE FLASH HEAD

Four ½" diameter mounting bolts should have been provided with the Flash equipment. Ensure the flash head is mounted on a level surface. If it is difficult to obtain a level surface, mount the flash head with three extended bolts with nuts on both sides of the flash head's base and adjust the three nut/bolt combinations together to achieve a level orientation of the flash head. Refer to Flash User Manual for details.

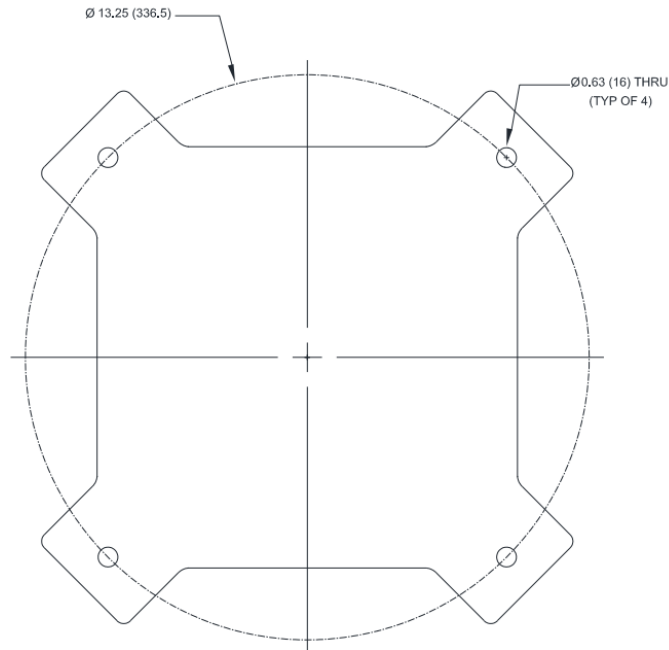

## MOUNTING THE PHOTODIODE

The photodiode should be mounted upright and ***facing due north***. In the base where the cable enters, there is ½" NPT threaded fitting that can be used to mount the photodiode. Alternatively, it can be zip tied in place.

## C. CONNECTING THE COMPONENTS

### CONNECTING THE SOLAR PANEL CABLES TO THE SOLAR PANEL

Loosen the rounded cable gland nut and pull about a 1 foot of cable through the nut to make it easy to work with when stripping the ends.

Strip about 2" from each end of the two solar panel cables.

Open the solar panel junction box.

Pop out the 2 knockouts to create entry openings for the cables.

For each of the two cables, remove cable gland nut, insert the cable gland into the junction box, and reattach and tighten the cable gland nut from the other side.

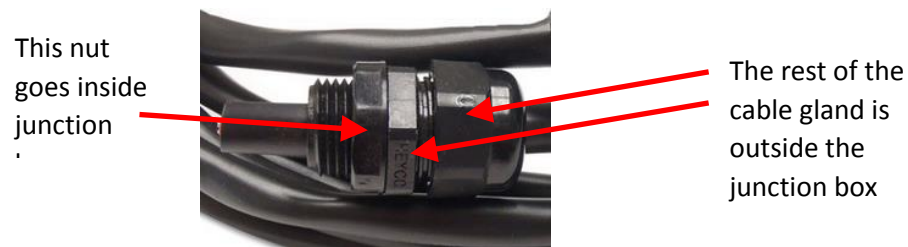

Connect the bare ends of the two wires to the solar panel junction box positive and negative positions as follows (according to image taken from solar panel spec sheet):

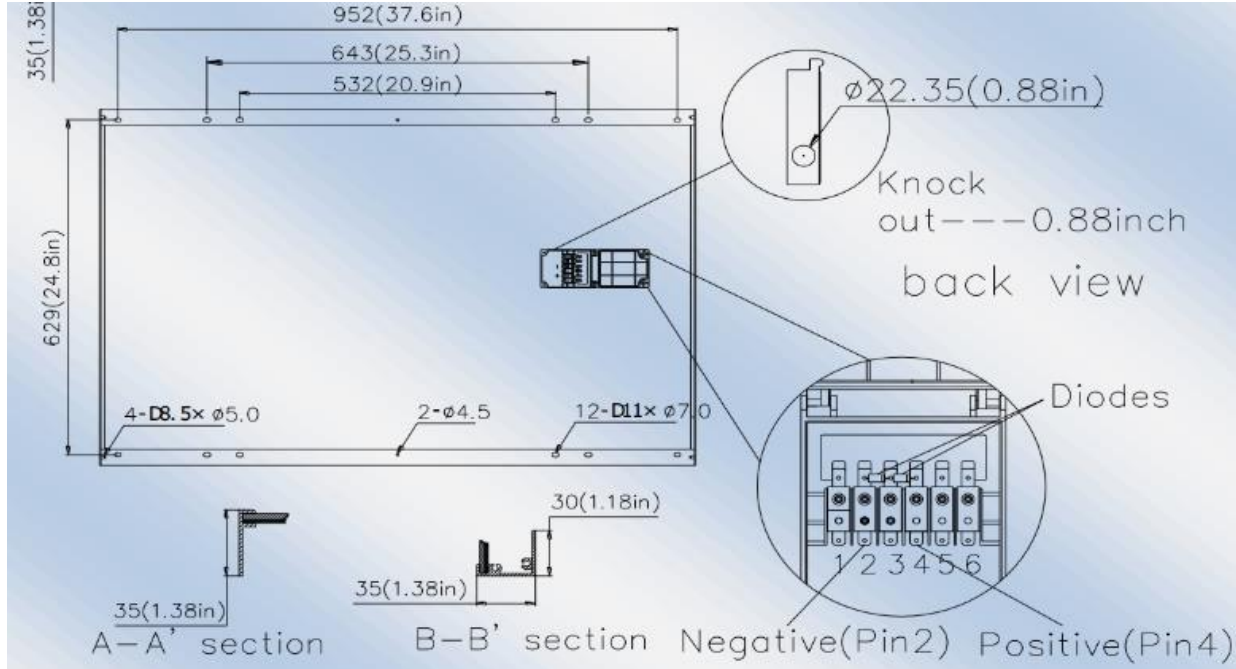

Tighten the rounded, external cable gland nuts to ensure the cable is held firmly in place and forms a watertight seal around the cable jacket.

**NOTE**

Both single-conductor cables that will be attached to the solar panel are black, so they will need to be labelled positive and negative to ensure they are connected with the correct polarity on the terminal block inside the enclosure.

**CONNECTING THE SOLAR PANEL TO THE ENCLOSURE**

Once the two solar panel cables are connected to the solar panel, the next step is to connect the other ends to the inside of the enclosure.

At the back bottom left of the enclosure, there are two (2) ½" knockouts that need to be removed. The solar panel cables will enter through these two holes.

**NOTE**

An additional cable entry hole will need to be drilled because the two individual solar panel cables will use up both the standard knockouts in the enclosure. Use a step drill to make a ½" hole in line and close to the other two holes. Ensure that the batteries, once in place, will not block the hole. The power cable for the FTS 371 Controller will use this hole, so you will need to obtain a cable gland for this connection.

Connect the positive and negative solar panel cable to the SOLAR+ and SOLAR- terminal blocks:

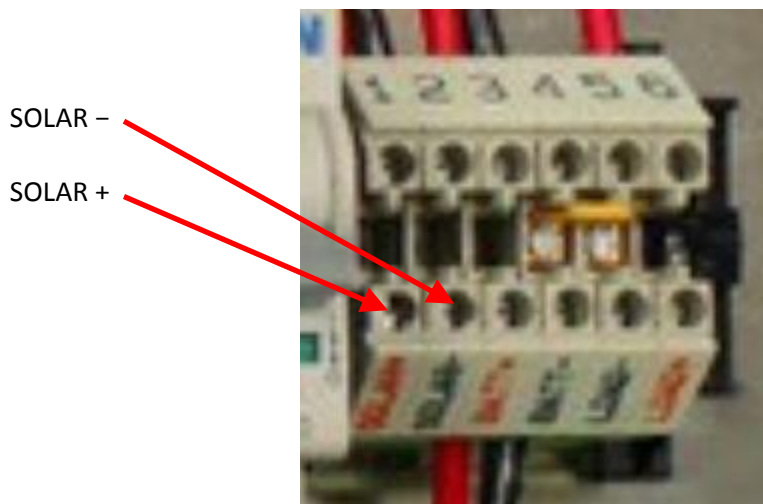
**CONNECTING CONTROLLER'S DC POWER CABLE****NOTE**

DC power cable to connect the FTS 371 FTC Controller to the solar system is **not** included and will need to be obtained by the end user. Use #12AWG gauge 2-conductor (red, black) with ground that is rated for outdoor use. The cable must be jacketed so that the cable gland can seal around it. Determine the required length based on the distance between the controller and the solar system enclosure plus some extra.

With the controller's three cable glands already installed at this point, bring the DC power cable into the controller using the left-most cable gland. Connect the power cable to the controller circuit board using the following terminal block J1:

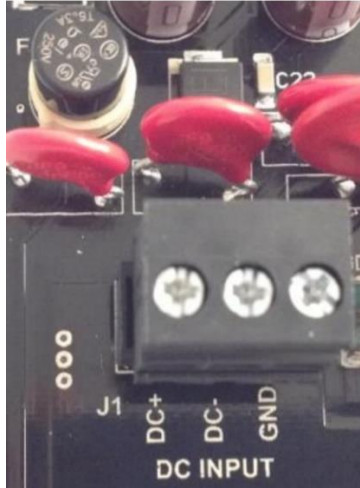

### CONNECTING THE CONTROLLER DC POWER CABLE TO THE SOLAR SYSTEM ENCLOSURE

Once the controller's DC power cable has been connected to the controller, the next step is to route and connect this cable to the enclosure. It will be connected to the LOAD+ and LOAD- terminal blocks on the DIN rail along with a ground connection. The enclosure terminal blocks provide power to the controller, which in turn provides power to the flash head.

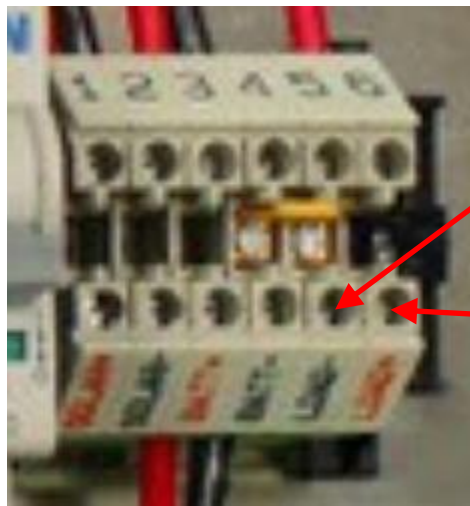

Controller Negative (Black)  
to LOAD-

Controller Positive (Red)  
to LOAD+

### CONNECTING THE BATTERIES INSIDE THE ENCLOSURE



Batteries are shipped fully charged. Use extreme caution when handling the batteries as they can generate hazardous short-circuit currents. Remove all jewelry (bracelets, metal-strap watches, etc.) before handling the batteries.

After the solar panels and the "load" (the Flash FTS 317 Controller) have been attached to the wiring backplate inside the enclosure, the last step is to connect the two batteries in series. There is a battery harness already connected to the terminal blocks, but before attaching it to the batteries, the two batteries first need to be linked together in series using the 12" #4AWG series link cable. This will combine their individual 12-volts into a total of 24-volts



Battery Link Cable

With the batteries positioned inside the enclosure, connect the negative of the first battery to the positive of the second battery.

After connecting the link cable, one unconnected battery terminal will be positive and the other unconnected terminal on the other battery will be negative. Connect the ring terminals of the red (positive) and black (negative) battery harness to the unconnected battery terminals. Ensure that the correct polarity is applied.

#### **CONNECTING THE FLASH HEAD CABLES TO THE FLASH HEAD**

The flash head is powered and controlled by the FTS 371 Controller. Each of the three Flash 371 flash heads shipped with 50 feet of #12AWG 3-conductor cable. The flash head is pre-fitted with a cable gland.

Loosen the rounded cable gland nut and pull about a 1 foot of cable through the nut and into the inside of the flash head to make it easy to work with when stripping the ends.

Strip the wire ends

Connect the wires to the flash head circuit board as follows:

<b>Wire Colour</b>	<b>Function</b>	<b>Connection Point</b>
Red	Positive	DC+
Black	Negative	DC-
Blue	Ground	Ground Lug near TB1

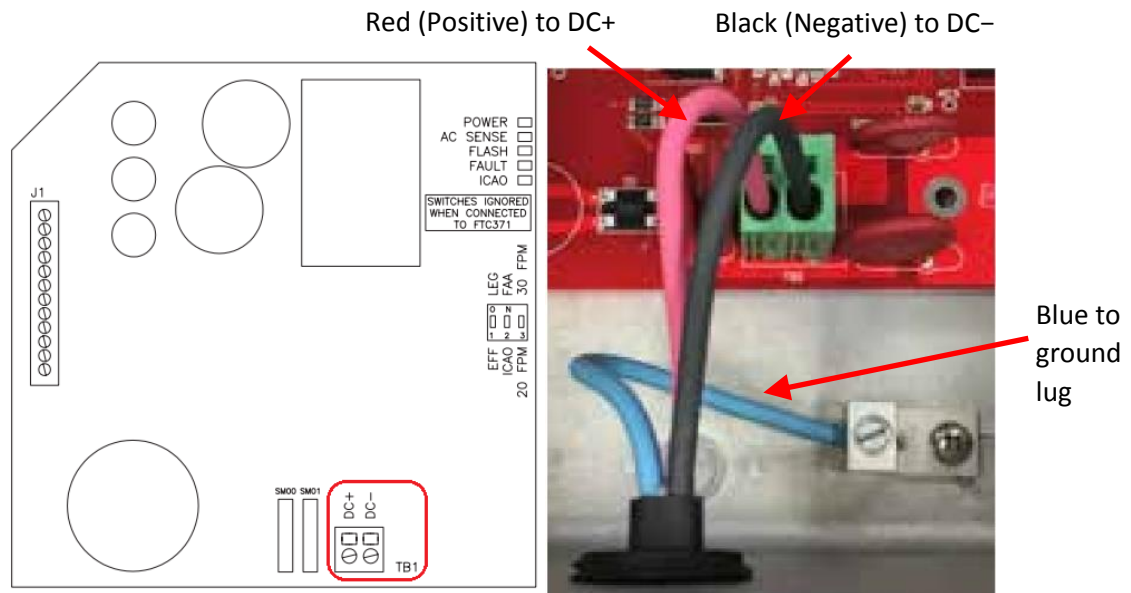

Flash Head Power Cable Connection Points

Pull any remaining slack back out through the cable gland and then tighten the nut.

See attached **“F7904219-FTS-371-Vanguard-QSG-DC-Basic-REV2.pdf”**

**NOTE**

The cable gland must form its watertight connection round the cable sheath. If you pull the cable back so far that the cable gland is squeezing down on the three individual conductors, it will not form a watertight seal when tightened.

**CONNECTING THE FLASH HEAD TO THE CONTROLLER**

Once the flash head’s power cable has been connected to the flash head and secured, the next step is to connect the other end of the cable to the FTS 371 FTC Controller.

With the controller’s three cable glands already installed at this point, bring the flash head power cable into the controller using the middle cable gland. Connect the flash head to the controller circuit board using terminal block J2 as follows:

Wire Colour	Function	Connection Point
Red	Positive	DC+
Black	Negative	DC-
Blue	Ground	GND

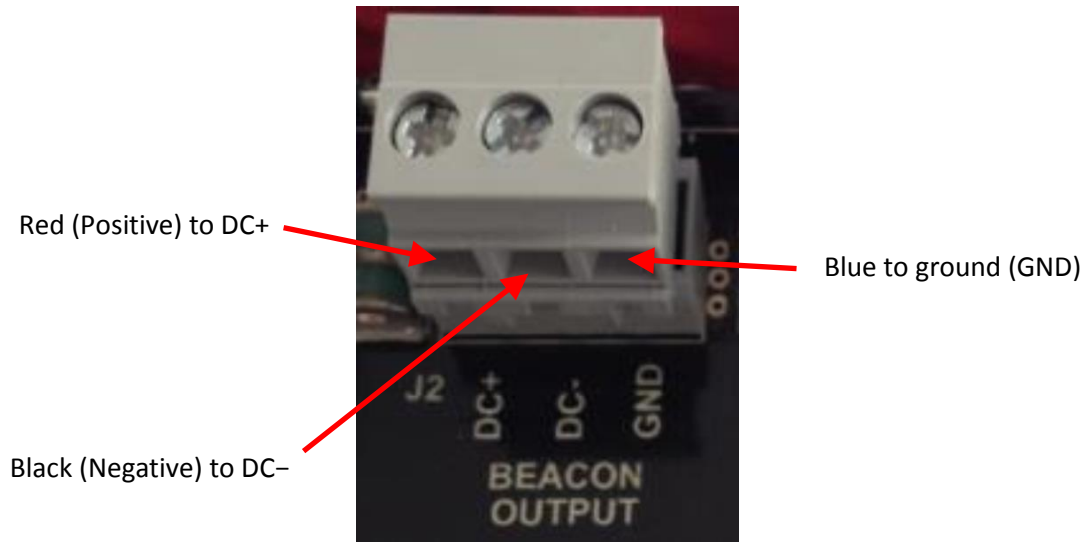

**CONNECTING THE PHOTODIODE TO THE CONTROLLER**

With the controller’s three cable glands already installed at this point, bring the photodiode cable into the controller using the right-most cable gland. Connect the photodiode to the controller circuit board using terminal block J4. The Alarm connection points in J4 are not used.

The photodiode cable is 2-conductor with braided shield. To connect the braided shield, peel it away from the white and black wires, twist it up and insert it into the SHLD connection of the terminal block.

Wire Colour/Type	Function	Connection Point
White	Photodiode positive (+)	WHT+
Black	Photodiode negative (-)	BLK-
Metal Braid	Ground (Shield)	SHLD



**NOTE**

There are no L-810 side markers or alarms used with this system, so nothing needs to be connected to those points on the terminal block.

## D. WIRING SCHEMATIC

